

BQ

Boomerang Quarterly, Winter 2006, Second issue

Texas LD Shoot-out	3
The Romance of the Boomerang	4
Methods for constructing Tribladers	8
Making a carbon fiber Boomerang	11
Pinch grip vs. Full grip	26



ABOUT BQ

This is the second issue of BQ. Response to the first issue has been great. I have people ask me if I would include their articles into BQ and the answer is: yes, of course!

If you have anything that might be of interest to the boomerang community, send it my way.

This time, there is a lot of emphasis on construction, especially composite boomerangs. However, there is interesting articles for you even if you don't care about step-by-step how to do articles.

I am still shocked at the amount of material I am able to find online.

Whenever I have time (lunch break) I tend to Google certain boomerang related terms and more and more interesting stuff shows up. It is sometimes really hard not to overdue an issue of BQ. Yes I am already working on the spring issue to make sure it arrives on time in your email-inbox (in March 2007). But you need not worry, I do have material for four interesting editions in 2007 and way beyond.

See you on the fields,
Tibor

CANBOOM

This year saw a few decent scores by Canadian throwers and some improvements to our national records.

There were six Canadians competing this year: Andy Cross, Emmanuel Dumont, Louis Derger, Tibor Horvath, Kelly Kuszner and Stephane Marguerite. That's not bad.

Best Canadian scores 2006	Score
Fast Catch	22.47 s
Endurance	54 C
Accuracy 100	74 P
Trick Catch/Doubling	85 P
MTA100	27 s
MTA3+	69 s
Aussie Round	80 P
Long Distance	130 m

As for our national team for 2008, I would love to have all interested Canadian throwers meet in 2007 and get to know each other, maybe even build some boomerangs together and certainly have all team events tried out and practiced.

My personal favorite would be a meeting in May in the Edmonton area (at least of all western Canadian throwers) and then meet again at Betsylew's competition in Seattle in June to learn how to support ourselves in a competition setting.

CANADIAN NATIONAL RECORDS

Event	Name	Results	Competition	Date
Aussie Round	Stephane Marguerite	81 P.	Burlington USA	July 2000
Accuracy 50	Stephane Marguerite	44 P.	Burlington USA	August 1997
Accuracy 100	Emmanuel Dumont	74 P.	Emmaus USA	October 2006
Fast Catch	Stephane Marguerite	19.99 s	Lausanne CH	2002
Endurance	Stephane Marguerite	66 C.	Lausanne CH	2002
Trick Catch	Tibor Horvath	85 P.	Seattle USA	September 2006
MTA 100	Andy Cross	40.84 s	Kiel D	2002
MTA unlimited	John Cross	66.00 s	Portland USA	unknown
Juggling	Eric Promislow	3 C.	Northampton USA	1992
Long Distance	Andy Cross	152 m	Houston USA	October 2004

TEXAS LD SHOOT-OUT IN HOUSTON | WYTHES— HORVATH — HIRSCH

TOM WYTHES 139M:

It was a great tourney and a great venue. The Shootout has got to be THE premiere LD event. The trophies are great and who else has a "Shootout Hook". I noticed my bag was searched at the airport but the Hook (my precious) made it safely. I wonder what homeland security thought when they found a stainless steel question mark. It is a testament to the organizers efforts that the tournament went so smooth. We got in 4 rounds the first day without trying. The spotting seemed really good and I think the spotting sticks helped.

TIBOR HORVATH 130M:

Wow, it sure was a great crowd, and a great field. This was LD heaven. A steady breeze and nice warm temperatures is all you can ask for, in an LD competition. Thanks for Stu and David to organize the whole thing. There is always much more involved than meets the eye of a competitor. I was very impressed (as usual) with the great spirit especially in willingness to go spotting. quality of spotting was also top notch. Position

and triangulation was the way it should be.

Tom sure got his boom dialed in and was profiting from the wind the most. He sure got me moving a lot when I was head spotter. His flight reminds me a lot of Schummy's Buzz Whip flights in St. Louis.

From my perspective, I was really happy to have scored a valid throw. My first round, I was using pinch grip, just to get into the groove. Then I switched to a 2 finger grip. It is not the first time for me throwing finger grip in recent days, but the first time throwing LD with finger grip. I definitely got more control the more I was

throwing. Some of the flights really went out there too. But while I did get returns in warm up, they did not want to cross the line in competition.

DAVID HIRSCH 121M:

Tom Wythes had a phenomenal tourney with the top three best throws at 131m, 135m and 139m... the dude was zoned in! Way to go Tom.

We had great weather, warm, highs in the low to mid 90s with an average wind of about 5 mph. Good and steady most of the time, with a few dead spots but overall ideal.

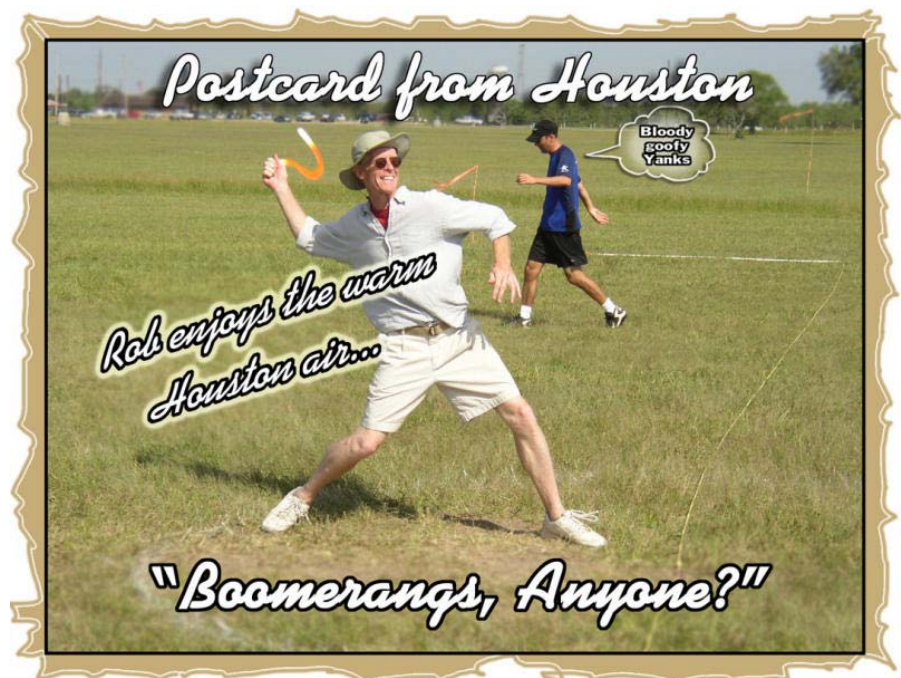

THE ROMANCE OF THE BOOMERANG | JEFF LEWRY

 "A weapon of the hunt or of war, and an artifact used in ceremonial rituals way back just this side of the dreamtime reached out of the past, grabbed me, and changed my life. It is awesome to consider Aboriginal Legends full of myth and magic from that shadowy time have touched me, changed me, and raised me out of the common, mundane world, given me a new trade, and released me from a job I did not like." - so I wrote to myself almost 30 years ago, when I was in the habit of keeping a diary.

As a lad growing up I had tried unsuccessfully to get boomerangs to return. Other kids used to bring along their new toys and we would throw and throw them without success. Finally I came to the conclusion that one had to be an Aborigine, or possess a special knack to get a return. I realize now that the so-called boomerangs we were trying were just sticks, and

there had been no attempt to make them properly. Later I still had the desire to see if boomerangs really worked, and perhaps throw one myself.

In 1963 I heard an interview on ABC radio, with Jack Byham, of Cobram, Victoria, who mentioned that he made boomerangs that DID return, so I wrote to Jack (who has since been a very good friend all these years) asking if he could supply me with one,

left-hand boomerang, which is a complete mirror-image of the right-handed model. The right-handed one spins and orbits anti-clockwise, and the left-hander spins and orbits in a clockwise fashion.

I was a master butcher at the time, but I did not particularly like butchering, nor following in my father's footsteps and his fathers. I had simply been roped into the family business when my

Jeff Lewry in his boomerang factory

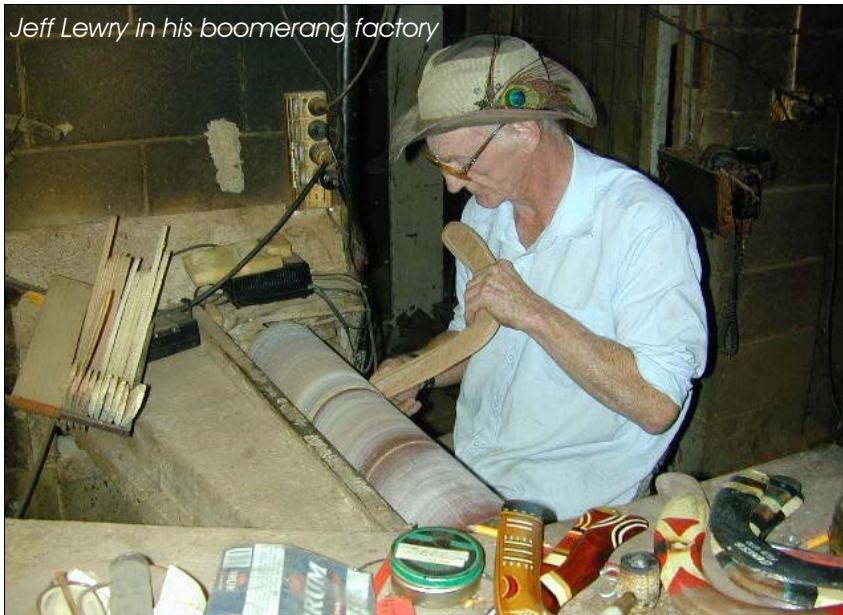

father sold out in Sydney and bought a shop in Albury. My hobby of woodturning helped me forget my distaste for my occupation, which I suppose I felt I would have to work at the rest of my life. Now I had an interesting

project on which to apply my woodwork skills: using Jack's boomerang as a pattern to construct a left-handed one.

What could be simpler? A boomerang is just a bent stick!

which he did for 25 shillings. He didn't ask, I didn't know, so he sent me a right-handed one, which made a beautiful arc into the ground each time I threw it.

Upon phoning Jack, I discovered that I needed a

I soon found out I was in error feeling this way - as I studied the situation and experimented, I discovered the difficulty of building "education" into a boomerang to make it return properly. Right away I had a renewed respect for Aborigines. Through design they had been able to programme a piece of timber to behave in a particular manner under certain circumstances!. So, here was I, a man of another time, skin colour and culture, attempting to learn two skills at once- throwing and designing. At one stage I didn't know if I was making good returners that I could'nt throw properly, or had taught myself to throw alright, but was making bad Boomerangs ...

After a lot of failures, I determined I was going to persevere, no matter how long it took, until I was making, and throwing, good boomerangs. I quickly learnt a lot of things not to do, but finally, through the process of elimination, I developed methods of making boomerangs that did, indeed, return. I sincerely believe that this learning the hard way, turned out to be a blessing in disguise, and has enabled me to rise to the top of my craft. Yet it is not a

system I would recommend to anyone, or inflict on a brown dog!

After I had become reasonably proficient at these twin arts, I found that when I went to the nearby sportsground to practice, all the kids turned up and wanted to throw. I was immediately embarrassed and disappointed when it became obvious that I could'nt be of help, except for the few left-handers. I corrected this by making some right-handers and taking them with me to give to the kids. Eventually, circumstances forced me to start asking for enough money for these Boomerangs to cover my expenses. (Does this sound familiar to anyone?) the crowds were getting larger!.

Thus my new hobby developed into a sideline, then a business..... Because after I got into some competitions, and became more active in this business of boomerangs, I found I no longer had the time or inclination to continue in the meat industry. In 1967 therefore I sold my butchers shop and took a long holiday, mostly traveling around and selling boomerangs.

Two years later I bought premises at Bowna on the Hume Highway, just north of Albury, from where I could better concentrate on boomerang manufacture, and woodturning, both of which I enjoyed a lot more than cutting up meat. From then until now I have

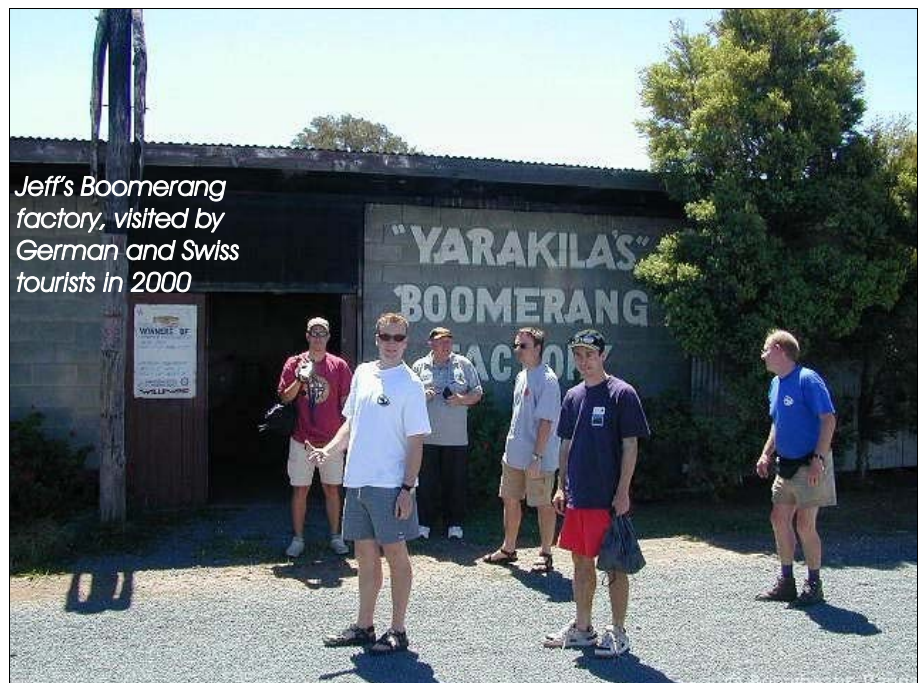

never ceased to marvel at that strange, almost mystical, magic from out of the past that wove the texture of my times, and the seemingly insignificant accidents and quirks of fate that shape our destinies. If I had known enough to ask Jack Byham for a left-hand Boomerang all those years ago, I feel sure I would have thrown it a few times until I satisfied myself that it did actually return, and then forgotten about the whole thing, having fulfilled a childhood dream. It was the frustration of a left-hander trying to make a right-hander's object work that led to the experimentation which got me just deeply enough involved to engage my interest totally. Boomerangs have certainly changed my life. I managed to win the World's Boomerang Throwing Championship six years in succession, before retiring, and I'm proud of it. It is a record that probably never will be equaled. I also managed to set both Australian and World records for distance throwing, back in the seventies, rating a mention in the Guinness Book of Records, but these have been improved on since. I have won the Australian Championship

twice, two of my sons Peter and Joe have won that event once each. My eldest daughter, Carol, was runner-up to me in the World's Championship two years in succession, when she was 14 and 15, beating all the other adult men.(and you can bet we didn't let them live that down too easily!). Carol has also won a number of



Jeff building another fabulous boomerang

competitions, against adult men.

The main reason for my success, and that of my children, in competition, has been due to an unusual shape boomerang that I designed. There is an interesting story to go with it too: In the 1850's an Aboriginal known locally as "King Billy" was thrown out of a

sly-grog joint on the banks of the Yarra, in Melbourne. In revenge he knocked the weather-vane off the end of the joint with his boomerang, for which he was hauled off to the lock-up by the local policeman. His boomerang was picked up and kept by another local (who apparently didn't go to gaol), to be eventually given by his descendants to Ralph Sinclair, when he won one of the first ever boomerang competitions, run by the Harold Blair Memorial Institute, in 1962. This boomerang, known ever since as "King Billy's Hook", is much too valuable to be thrown, but it has been copied. "Speed" Maxwell of Melbourne gave me a copy he had adapted to his own shape, which I found inconsistent in returns, and cumbersome to throw. I was ready to give it up, when happily I reduced the width of the arms, and lightened the whole thing off, finishing with an excellent boomerang at this stage I had never seen Ralph's hook. Imagine my surprise when I later handled the famous boomerang, to find my design, adapted from Speed's, was almost exactly the same shape as the original - that magical hand from the past again!

I have been able to meet interesting and sometimes famous people from all around the world, and my boomerangs have gone to any country you can think of. I have taught Gina Lollabrigida how to throw, and the captains of the English and Zimbabwe cricket teams, also the Australian Minister of Defence, plus Lt.-Generals and colonels of Syrian and Arabian armies (must be a moral in there somewhere) I have had the World Champion clay-pigeon shooter (an Englishman) try to blast my boomerang out of the sky with a 12 - gauge, and miss in 4 rounds. All have been mesmerised by the peculiar fascination of returning

boomerangs. I have never yet met the person who could throw a boomerang just once.

In New Zealand where I had a 2 weeks all-expenses paid trip, as a result of winning the 1970 World's Championship, I was asked to give a demonstration for the Governor-General. Which was unusual in that he had

to come and see me, on the sports ground in Wellington, not me go to see him, the more usual way with command performances. A more gracious gentleman I have yet to meet.

Also in Wellington I gave a demo for 120,000 rugby fans, when the South African "Springboks" were playing the English "Lions". This was a novelty, in that the committee had to have a special

came to see me make a fool of myself, not really believing that boomerangs return. We started with an hilarious interlude of me teaching some local celebrities how to throw, followed by a couple of locals who brought their own boomerangs to show off, or show me up, I'm still not sure which. One right-hander was flabbergasted when he

could't get his boomerang to come back to him, yet I could by throwing it inside out with my left hand. He told me that what I did was impossible, and left shaking his head.

My main aim was to improve on two of my own records, one for

Two long distance world champions comparing notes. Manuel Schuetz on the left and Jeff Lewry on the right.



meeting to decide whether or not a Boomerang-Thrower could be allowed to tread the hallowed turf at half-time. I responded by converting a try through the goal posts with a boomerang, several times. Ten thousand people turned up at Palmerston North, where the only item on the programme was me throwing boomerangs. I feel sure they

catching, the other for distance, although it seemed I threw far enough to better the distance mark, in early practice, I failed both when the time came later. The wind was against me. I was bitterly disappointed, I would have liked to add to the history of the day, by setting new marks on other than Australian soil.

METHODS FOR CONSTRUCTING TRIBLADERS | ROBERT X. QUINN

 Tri-bladers have recently been very popular both on the field and in newsletters. This past summer (1992), I constructed 21 different models incorporating different aerodynamic parameters (chord width, wood thickness and blade length). The following are notes I compiled with the help of the Bay State Boomerang Society.

The thing I find that works best is to cut a design from poster board and then make a tracing of it on wood.

Start by making an equilateral triangle with sides 3.5 inches (90 mm) each. From the midpoint of each side, draw a line to the opposite apex. From the center of the triangle draw a line through each apex 6-1/8" (155 mm) in length. From this configuration, several different tri-bladers can be made from

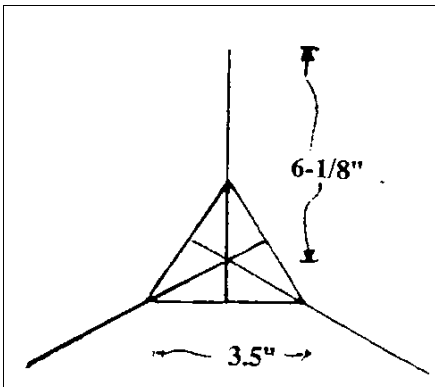

4 mm wood.

Boom #1

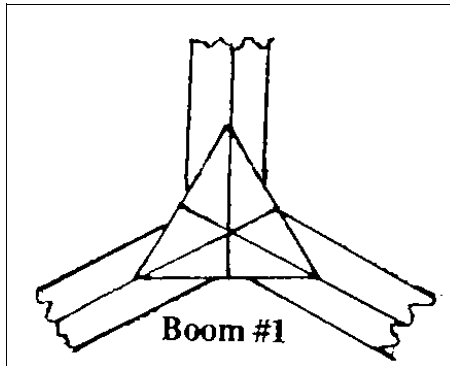

You can make your basic tri-blader by drawing parallel lines 5/8" (16 mm) away from the center line. This rang is a little slower than the others, but a lot more consistent and easier to throw.

Boom #2

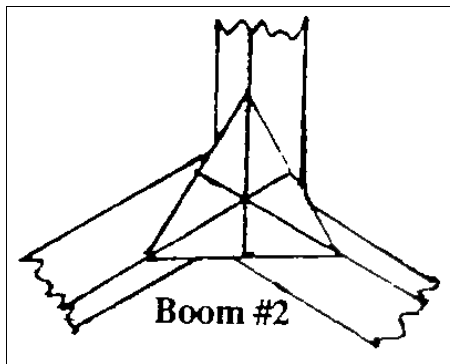

This boom has its center of lift in line with its center of rotation. Draw a parallel line 6/16" (8 mm) to the left and 15/16" (24 mm) to the right of the center. (This is for a right

handed boomerang. Reverse left and right for a lefty.)

Boom #3

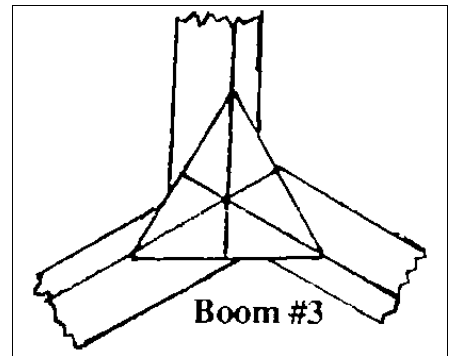

This boom is made by inverting boom #2. This rang climbs high and hovers. Good kid's rang, for count-up, or for outside doubler.

Boom #4

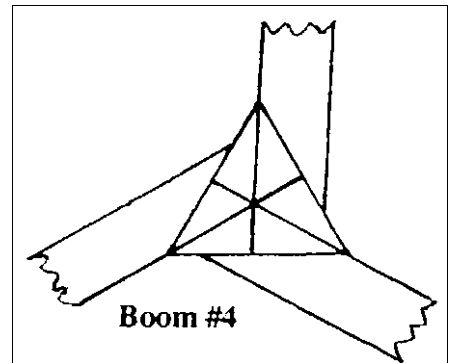

If you draw a parallel line 1-1/4" (32 mm) to the right of the center line, you have a rang with the leading edge in line with the center of rotation. This is similar to the one Rob Parkins used in setting his

records last season. (The Matthieu Weber 'rang.)

General Notes

When copying the design on wood, one of the blades should have it's grain running perpendicular to the blade. This makes it easier to tune later.

Increasing the blade length by 1/2" gives the rang more torque, making it easier to throw, but also decreasing the range.

Boom #3 might have trouble going 20 meters when made of 4 ply wood.

As a rule of thumb, increase the blade length by 1/2" (13 mm) and the chord width by 1/4" (6.5 mm) for each mm of wood thicker than 4 mm. You can make the triangle smaller for a good doubler or count-up, but this also decreases your distance.

Wider chord widths produce less lift, more range and more inertia. Narrower chord widths produce more lift, torque and drag and less range.

Tip construction

Bulbous tips and tips bent forward or backward alter the amount of lift of the tip relative to the blade. The tips are the fastest moving part of the boomerang and it's

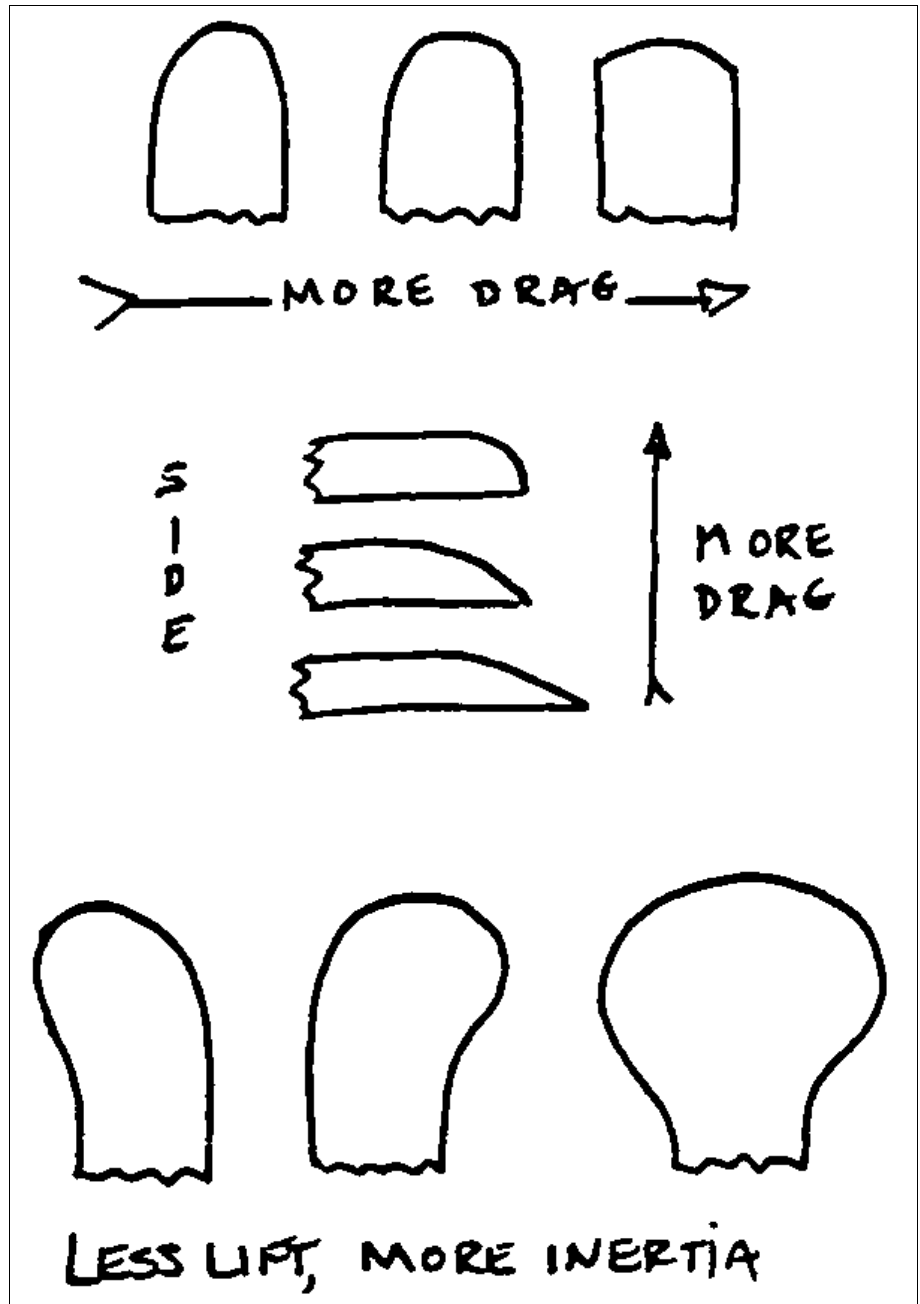

where a lot of the aerodynamic action takes place. For example, I made a standard tri-blader which had no airfoil on the last 5/8" on each tip. It required a hard throw and produced a level flight of 22 - 25 meters in under four seconds. When I shaped an airfoil

on each tips, it's flight was far less than 20 meters and it came over my head with less of a throw.

Airfoils

Count-up/Doubler Boom

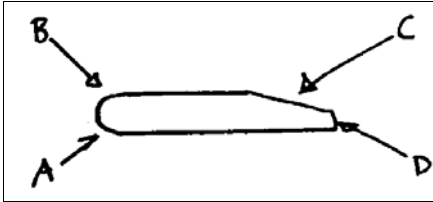

- A,B: slightly rounded
- C: 15 - 20 degrees
- D: should be 25% or less of total thickness

Fast Catch Boom

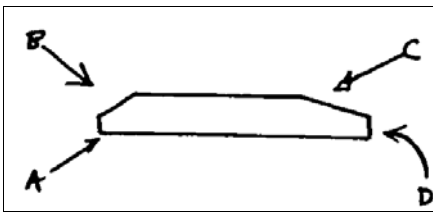

- A: none
- B: 35 - 45 degrees
- C: 20 - 25 degrees
- D: not less than 50% of wood's thickness

Start with these basic shapes and modify them on the field. Testing and trouble shooting should be done under ideal wind conditions.

Tuning the Fast Catch

The fast catch tri-blader relies on a balance of lift, torque, drag, speed and spin to obtain an ideal flight. They require a consistent throw as well as consistent wind conditions. Any major variations

of these can cause disastrous results. While favorable winds can only be prayed for, making your own rang at least gives you the luxury of matching your own throwing style. (Note: always warm-up before throwing fast catches and always protect your eyes and hands)

Basically, lift and torque determine how high and tight the flight will be. Drag allows the thrower to throw with more velocity and keep the boomerang level, but it also slows it down. All of these forces work together. You cannot alter one without altering another. Following are some tips ranging from simple to drastic. Altering angle of attack and/or dihedral to one or more wings can dramatically alter the boomerang's flight. Fast Catch tri-bladers usually require a hard vertical throw 90 degrees off wind.

Crashes before returning

Throw harder or less vertically.
Positive dihedral on one or more blades.
Take off wood at C, making D thinner.
Decrease angle of your tips.
Make a model with longer arms.

Flies over your head

Throw softer or more vertically.
Add a flap to center.
Add negative dihedral to one

arm.

Add some lead tape to center or tips.
Drill holes in center (of wings).

Flight greater than 25 meters

Take wood off at C, making D thinner.
Take wood off at A (Might come in over your head)
Shorten chord width, shaving a little off leading edge.
Make another model with longer arms.
Twist in positive angle of attack at tips.

Flight less than 20 meters

Add some lead tape to center or to tips.
Take wood off at B.
Shorten blade length. (May cause 'rang to come in front of you)
Twist in negative angle of attack at tips.

Rang comes in front (like figure 9)

Throw it 1-2 o'clock or with more lay-over.
Add lead tape to tips.

Run out of spin

Throw with more snap.
Decrease the angle at tips.
Take wood off at B.

MAKING A CARBON FIBER BOOMERANG | ADAM MCLAUGHLIN & MARTIN LASLETT



Here is a real first.

One of my original ideas for a website, was to have a step by step guide to making your own carbon fibre boomerangs, preferably an MTA. There is no website anywhere that contains the precise step by step instructions to do this. I have found, and still find, that information on construction techniques seems almost secretive. Imagine a boomerang world in which only a handful of people could make wooden/paxolin boomerangs. Not good I think...

I wanted to change all this, and have been itching to start my own carbon fibre construction.

So here it is! - the detailed step by step instructions - for the beginner, with over 70 clear photos.

I have shown these techniques, hoping that new people may start to experiment and pave the way for new fantastic flying MTA's. I am very grateful to Martin Laslett, from Birmingham UK, for teaching and showing these methods, as it was his many previous failures that lead to the following steps. He is a true master of experi-

mentation, and is unselfish in the sharing of what he has found. Thanks Mart.

Martin said, ' So...we are the Penn and Teller of carbon MTA's', which I thought was quite apt.....!

Also thanks to Pierre Kutek, for his advice and very helpful Emails. Pierres carbon fibre boomerangs are fabulous. Thanks also to the patience and advice from the friendly staff at www.polyfibre.co.uk ...

Before you read on, please note the following:

1. Working with carbon fibre, and the resins can be naaasty. This stuff is to be respected. Wear Gloves and Mask, and goggles.



2. Work in a well ventilated

area.

3. Be organised, work tidily and safely
4. Keep children away from the work area.
5. There is a very real possibility of catastrophic damage to your MTA you are attempting to mold. Mistakes WILL happen, expect this.
6. The methods we are about to show, are what we have found after 2 years of trial and error. There are almost certainly better methods out there. If you know of any improvements please EMail me! You will find, there are loads of things to find out and try.
7. There are many different types of resin, and they can be used in different ways. There is no definite 'do this, and do that'. There are some very good Websites (see my links), about carbon fibre. Visit these to get an appreciation of what its all about.
8. I bought a good beginners book, available at Amazon. *Fiberglass and Composite Materials* by Forbes D Aird. I recommend this. Remember

there can be major health and safety risks associated with this. Have fun but be mindful.

9. I accept no responsibility for any trouble you get yourself into! We are NOT experts.
10. I welcome any comments and questions.

"He who asks is a fool for five minutes, but he who does not ask remains a fool forever."

-- Proverb

Carbon Fibre basics

As far as making carbon fibre MTA's, this is a brief overview of the process involved. First you need to decide on the type of resin, to make the mold out of. Without going into too much detail, the resin that we currently use, is Poly urethane. In the past, we have tried Epoxy resin, which is a lot harder (i.e. tensile hardness), than Poly. I think Poly is easier to make a mold from.

Poly urethane's disadvantage for a mold material, is that it is more easily damaged/scratched, and therefore less boomerangs are going to be made from it. Next decide which

boomerang to make a carbon fibre copy of. In my pictures, I have chosen a 1.5mm paxolin MTA.

There are 2 techniques that Martin has developed to help construct a mold. The plasticine method, and the tape method. In this example we have used the tape method, because the MTA is so thin.

The plasticine method will be explained in a separate instruction. We then make a mold.

Next the mold is filled with carbon fibre. At this point, in my article we also used a vacuum bag. This is not essential, but we think a better finish is produced on the final surface

of the MTA if it is used. Next we add microballons/ and maybe some balsa. The two halves of the mold are then pushed together, and with pressure, left to set, at room temperature. At this stage of our current experiments, we do not use any heat to help the curing process.

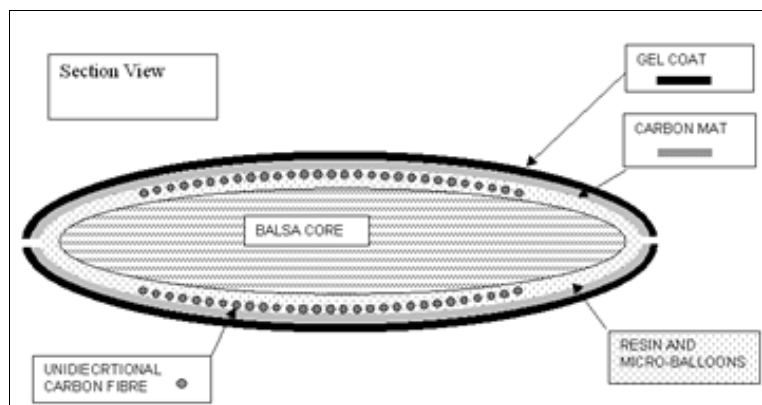

If successful, the mold is separated, and out pops a virtually ready to fly, carbon fibre MTA.

Oh Joy.

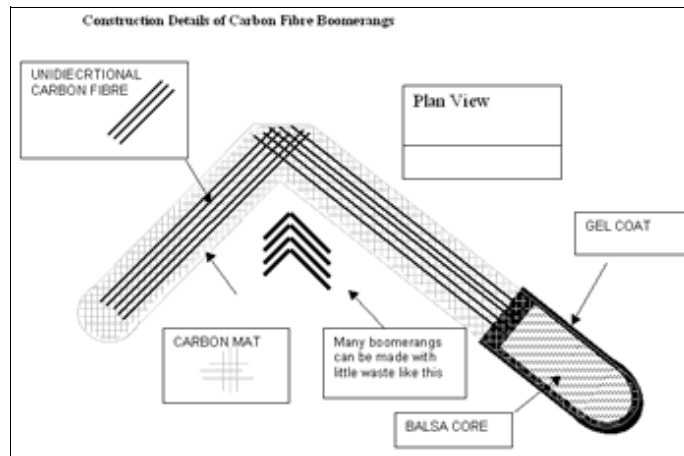

Stages

I have split the construction process into different areas to help make this easier to study. If my instructions are unclear, please Email me, and I will clarify the process being queried.

Shopping List	What its for?	Is it essential?	Cost
Boomerang	Needed to form the mold	Yes!	NA
Carbon Fibre	Gives strength to the Resin	Yes	£20 metre
Vinyl ester	Resin used to impregnate the carbon fibre.	Yes	£10 2kg
Gel Coat	Forms the outer surface of the MTA	No	£5 1kg
Hardener	Makes the resin go hard	Yes	£6
Uni tape	Gives added strength to the boomerangs arms	Unsure	£2.25 metre
Masking and sellotape	Various uses during mold and boomerang construction	Yes	NA
Film pots	These empty film canisters are handy to pour the resins into, whilst you are using them.	Yes or something similar	Free
Vacuum Pump	Used to do the vacuum bagging	No	£££
Balsa wood	Balsa fills the gap between the upper and lower surface of the MTA. Its light, and has no strength. A gap filler only	Yes. Some people may use other light materials as a gap filler.	Cheap
Microballoons	Used to help fill the MTA. Mixed with resin. Helps the shells to stick together and helps to fill the spaces inside the MTA with light material	Yes	
Scissors	Various during construction	Yes	NA
Scalpel type blade	Used during mold construction	Yes	NA
Chisel	Used during mold construction	Yes, and make sure its very sharp.	NA
Pen/ Paper (A3)	Various	Yes	NA
MDF wood 1cm or similar	Used for Mold construction	Yes	NA
Mask/Goggles/ and disposable gloves	Used during Mold and construction process	Gloves - Yes. Mask - depending on your ventilation setup. Goggles - Yes	NA
Wax	Makes things separate that you don't want to stick together	Yes !	£5
Peel Ply	Used as part of the vacuum bagging process	No	£2 metre
Breather	Used as part of the vacuum bagging process	No	£1 metre
Brushes	Used to apply resin to molds or carbon fibre	Yes	NA
Bin	You will get a suprising amount of rubbish. Dont use your best bin	Yes	NA
Ventilator	Mart uses a cooker hood, attached to a extractor pipe	No, work in a well ventilated area though.	NA
Syringe measure	Used to fairly accurately measure hardener quantities	Yes or something similar	£1
Black Pigment	Used to colour 1. The microballoons(So they are not obvious on the finished MTA) and 2.To make it easy to see when painting on the Gel coat	No	£2
PolyKast (Polyerethane)	Used to make the mold	Yes. Unless you make the mold from another resin	£20
Vacuum Bag	Air tight bag used to contain the mold during the vacuum bagging process	No	NA
Styrene	Clean your brushes	Yes	£5
Plastic stirrers	Mix resins	Yes	NA
Drill / Jigsaw	Making of molds, and mixing of resins	Yes	NA
Fan	Aids ventilation	No	NA
Kitchen Roll	General Cleaning !	Yes	NA
Clamps	Pressures the filled molds together, to produce the finished article.	No. Then use a heavy weight.	NA
Bagging sealant tape	Used to seal the Vacuum bag.	No	NA
Wooden Base 2"	Used to put either side of the molds during the clamping process	Yes	NA

You will also need lots of patience, and 20 cl of luck.

Making the Mold- (time 2-3 hrs)

Making the mold is fairly easy, and you haven't the worry of tight time targets as when laying up the boomerang.

1. Draw around the boomerang onto some MDF. The MDF is approx 1 cm thick. Then do a second line around this outline allowing about 2cm. This piece will become the top of the MOLD CONTAINER.

2. Draw around the boomerang again, this time, just 1 line. This piece of wood will become the bottom of the Mold Container

Note - ensure this bottom piece of MDF is absolutely flat, since any warp will throw out the tune of the boomerang when it is produced from the mold.



3. Cut out the outer line on the left hand outline in the above picture, and separate the pieces of wood that are to become the upper and lower sections of the mold container. Now screw these together so they are tightly joined.



Join upper and lower sections after cutting.

4. Now go and throw your boomerang. Work out in millimeters, how much tune is needed for each tip. Record this. If you look carefully you will see numbers on my boomerang. This is tuning information.

5. Apply a coat of wax to the boomerang. Allow 20 minutes to dry. Now buff it with a paper towel. Apply a 2nd coat. Allow to dry and buff.

With a black pen, draw onto the boomerang, onto the center line, all around the edge of the boomerang. i.e. draw a black line all around the boomerangs edge. A thin line about 0.3 mm thick is visible on both the top and bottom surface, this will help find the edge if it gets buried in the

mold later on.. Now tune the boomerang.

6. Wax up the mold container. Pay particular attention to the edges of the top surface. Also wax the upper surface of the mold container. Ensure nothing is missed. One coat should be enough. In the picture, you can see the tin of wax in the background.



Wax up the container

7. With narrow masking tape apply around the edge of the boomerang, roughly so that half of the tape is above the edge, and half below. Note that in the pictures, we used sellotape, but we found that the resin caused it to unstick a little. Masking tape should be better.



Sellotape the edge of the boomerang, all the way round.

8. Place the boomerang upside down, taking care not to bend the boomerang, or mess up the tape. Place it onto a disposable hard surface (we used a tile).

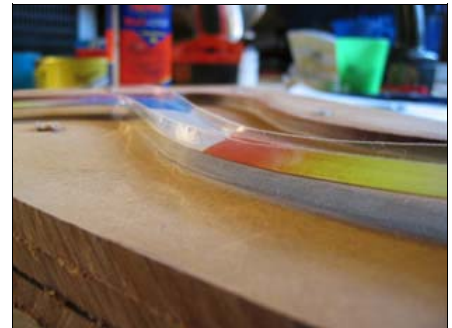

Here the taped up boom is ready to receive the first pour, (needs turning upside down)

Put on your disposable gloves.

Now get some Polykast. This resin is going to make the mold. It is supplied in 2 separate parts, which we call Polykast A and Polykast B - it is mixed in equal quantities. Fill an empty film canister about 1/2 full with Polykast A, (its actually 30 ml to the brim) - we got the film canisters free from a photographic developing shop. Pour this 1/2 into a separate plastic beaker.

Refill the film container with the same amount of Polykast B. Add to beaker

Mix the beaker contents thoroughly. We use a drill, with a stirrer attached, to gently mix

the contents for a few seconds. **This has a working time of about 5-10 minutes !!**

9. Pour a little of the mixture into the boomerang, enough to cover the whole surface, but not all the way up to the top of the sellotape. This is because as the mixture hardens, it gives off heat. As it sets it turns an opaque white colour. Too much heat is bad. You may find little leaks springing up here. Don't panic, just try to gently hold the tape in place until it has started to set. Now as the first pour is *just starting* to turn white, mix up another 2 parts of polykast. Try to time this just as its starting to go white, since if it completely sets this 2nd pour will not stick to the first pour. Again transfer to beaker and mix. Pour some more into the boomerang. This won't leak so much, as the first has started to harden. The aim is for approx 5-6 mm of resin onto the boom surface. In the picture below, our red beaker contains the 2 mixtures. The film container is also

visible. The boomerang on the tile is also visible. Also you can see we are topping up the first pour, which is already going white...



2nd pour



The 2nd pour. Note whitetish first pour

10. Wait until the resin has gone white, then remove the sellotape, and carefully trim away the leaked resin from the top surface. Use a razor to do this. Aim to end up with a clean upper surface, and the resin and sellotape all trimmed to the centerline of the boomerang. The picture clearly shows this.



Use a blade to trim precisely



Here the surface is nearly cleaned/trimmed

11. Now you have a boomerang which is clean on one side (the upper), and has resin stuck the other side. Now with a blade, scour the surface of the resin which is stuck to the boomerang. Try during all of this process, not to bend the boomerang. The scouring aids adhesion in the next step.



Scour the surface



After the first pour (yes its leaking!)



Clean up the leaked surface, remove tape

12. Retape the boomerang, with sellotape, not masking tape. Do *not* extend past the resin, on the lower surface. Start the tape at the resin, to

extend past the center line and into the upper half. Sounds complicated, but this picture clearly shows what I mean.

Hmm untried idea - I wonder if using masking tape instead of sellotape and drawing a black line on, for the centre line, would make it easier to judge the pour must try...



The boomerang is retaped, from the bottom of the resin surface

13. Mix up some more Porakast. Fill the film containers to the brim this time. Same process - A then B, then transfer to beaker. Now mix, and pour into the Mold container, aim for 5mm of coverage approx. As long as the entire base of the container has resin all over it. Now immediately place the boomerang the right side up, into the container.



The boom is placed resin side down, into the resin filled mold

14. As the boomerang sits in the mold, the highest point of the boomerang, should be around half the thickness of the MDF. It should not extend into the top surface of the mold. If it does, don't worry, we can deal with it shortly. Now mix up another 30 ml (full film canister) of Porakast.

Pour around the boomerang - not inside it!. Pour slowly and carefully, you want the resin up to the center line of the boomerang. The tape stops it going onto the boomerangs surface. Try to tilt the container to allow for the resin to deal with the dihedral (bend) of the boomerangs arms. The aim here is not to overfill the container. You will find that some resin will inevitably go above the center line but try to minimize.

You will also find that as the resin sets, some resin will not have reached the center line, that is also OK. Try to make as best as you can here. Let it go white.

15. Now examine the con-



The resin is topped up to the centerline

tainer and work out which areas need additional resin to meet the center line of the boomerang. With a pen mark the white resin roughly. See Pictures.



The resin has set, now check to see where not enough has gone

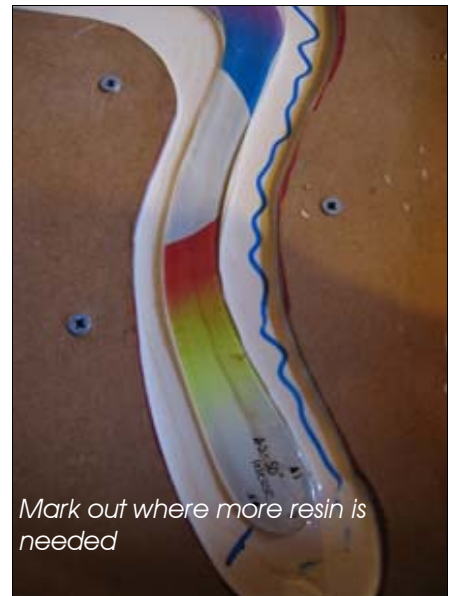

Mark out where more resin is needed



Here you can clearly see where too much resin sets on the tape - it should ideally be up to the center-line only

16. Where you have determined where more resin is needed, scour the now white - set resins surface, then mix up some more resin.

This scouring is important, since new resin does not stick to set resin very well.

With care, and tilting the mold container, get this resin up to the centerline of the boomerang. You shouldn't need to repeat this process again, but if after setting you find you still have a shortfall of resin, up to the centerline, then mix up a little more resin, and add some more. Don't forget to scour the surface first.

17. Now let the resin go nice and hard, say leave for a good hour. What we now have is the boomerang embedded in set resin, up to the center line of the wings. With a scalpel blade, carefully trim away the sellotape.

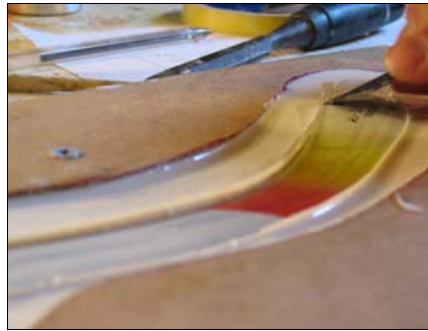

Trimming away the sellotape

What we now need to do, is to remove all the excess resin - i.e. where the resin went too high, and is above the center line. To do this use a nice sharp chisel. (In fact we had to keep sharpening this on an oiled stone, it really helped).

The resin carves away quite easily and cleanly. Try not to gouge the surface. The more time, and effort you put in at this stage, the better the quality of your final mold. Take great care not to accidentally pop the boomerang out of the resin., trim that resin back to the centerline The black line that you previously drew on the booms edge, should make it easier to see where the centerline



Pare back resin to the centerline

is!

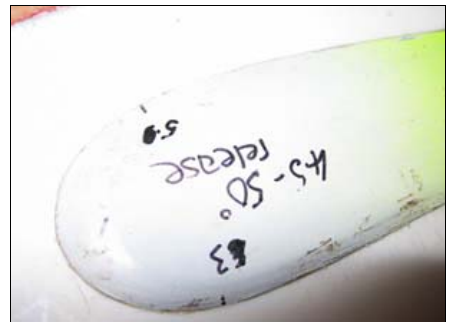

Close up, all pared back and ready

19. Now we are left with a boomerang embedded in resin, exactly up to the centerline of the boomerang. Now drill 3 locator holes in the resin, but not too deep. This is essential to ensure that the top half of the mold precisely locates to the bottom half. One at the elbow and two at the tips.



Drill the locator holes



Close up of the locator hole, not too deep...

20. I cannot show you a picture of this, because we forgot to do this stage! , but its handy....

Drill another locator hole, right by where the resin touches the wood of the mold. Then fill this little hole with plasticine, so it is flush with the resin again. This will help when you come to the mold separation shortly....

21. Now give the boomerang and resin surface a good wax, leave it to dry for 10 minutes, and buff it up. Pay attention to waxing the locator holes. Obviously don't wax the bit of plasticine.

22. Now mix up some more resin, say another full film pot of each (A and B), and pour this into the waxed up boom/resin. The idea here is to get the resin pretty close to the top of the wooden mold, but it doesn't have to be perfect. If you find the boom actually extends above the top surface, undo the screws, and wiggle the wooden mold up a few millimeters, but still keep-

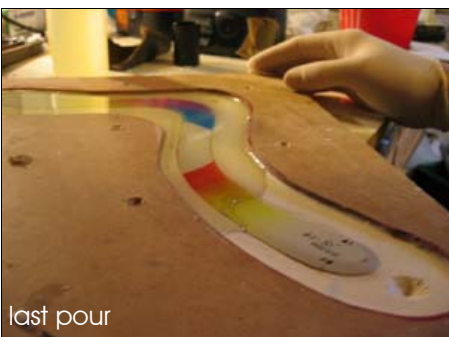

last pour

ing the resin contained within its edges. This effectively lowers the boomerang, meaning it can now be covered in resin...



Last pour, now starting to go white .Goodbye Boom...

23. Now let all the resin go hard. Once all the resin has set (20 minutes or so) , feel the top of the resin - it may still be slightly warm. Once you can hardly feel this warmth, its time to separate the mold. Unscrew the top wooden container, and ease out the



prize apart the mold

white, joined mold halves.



easy does it.....

Locate the plasticine I asked you to put in place, in step 20. Remove this divot. Now you have a handy gap to ease the mold apart.

With a chisel or similar, gently prize the mold apart. As you are doing this, try to look inside to see what is happening to the boomerang. With a little teasing, you will end up with the mold separated, and probably the boomerang still stuck in.

Now gently tease the boomerang out of the mold. Next clean up the mold surface, which may have accumulated some paint from the boomerang. take care not to damage or scratch the mold surface.

24. De wax the boomerang, and check the mold surface for defects. Fill /Repair any air bubble cavities.



Somehow the boomerang survives!.....

25. One final thing to do, is to carve 3 grooves into the mold, lower surface. Use the chisel to do this. Do one at the elbow, and one at the tips of the mold. These grooves will allow excess resin to escape during the clamping process. In this picture you can see the grooves.



The grooves let out resin during clamping



One finished mold.....

Making a carbon Fibre MTA- (Time 1.5 hrs)

OK, we've now got you to the stage where you have made a mold. Now how to make a boomerang. In these instructions, we also used a vacuum bag. However if you don't have the vacuum bagging facilities, you would miss this whole section out, and join the two halves together, all in one session. The mold we are using will produce a Gradus copy. The most tricky part I have found, is having cut the carbon fibre, and then laying it in the Gelled mold, you must peel away the paper, without stretching the carbon fibre. Its very delicate. Also if the Gel coat sets too fast, it can ruin things. Onward.



Ensure the mold is thoroughly waxed- both halves!

1. Ensure both halves of the mold has a thorough wax coat applied. It is recommended for the new mold, 3 coats of wax. For a mold that has already been used, then one coat will be sufficient. Leave each coat to dry before buffing up.

2. Preparing the carbon fibre, and peel ply..... On a piece of A3 paper, draw around the boomerang upside down, 3 times. Two outlines are for the carbon material, and the 3rd is for the balsa. Repeat onto the peel ply, but only twice. Then cut out the peel ply shapes. The picture clearly shows the A3 paper, that has the outlines on.



The prepared A3 paper

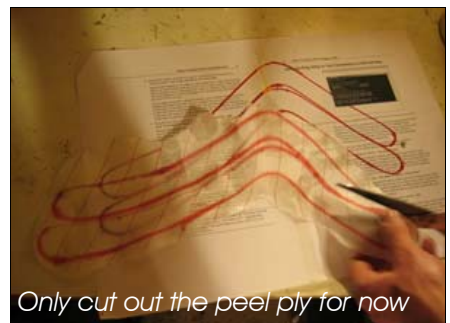

Only cut out the peel ply for now

3. Preparing the Balsa core....
Cut out the balsa outline from the A3 paper. Notice the line across the elbow. When cutting, cut slightly *inside* the



Cutting out the balsa line - about 3-4 mm. Cut the paper outline in half, across the line at the elbow. Lay these onto some balsa, draw around, and using a razor, cut them out.



Sanding the balsa



The balsa has been sanded

Then with some sand paper, give the balsa a crude airfoil shape (only so it fits inside the shells better)

4. Prepare the Carbon Fibre Uni-Directional Tape....
This tape gives extra strength to the arms of the boomerang. Uni tape is horrible when you cut it, as it frays really easily. Hint- wherever you plan to cut this material, stick a piece of masking tape. The cut ends are kept tidy. Unroll a piece slightly less than the length of the long and short arm of the MTA added together- so about 18 inches in this example. Cut this off the roll.

This now needs to be cut into two. To find this, hold the uni tape up to the boomerang, and hold your thumb where the elbow of the boomerang is. Put the masking tape where the uni tape will be cut, then cut.

Fold the uni tape along its length, into the centreline of itself - see pictures for clarifi-

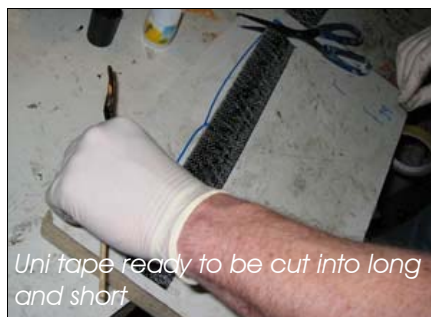

Uni tape ready to be cut into long and short

cation. Now cut down the center, along the length of the uni tape (see Pictures).



Tape is folded in to its centre

Put this prepared uni tape safely to one side. 5. Mix up some Gel coat. Hint - fill an empty film pot with styrene now, to put your dirty paintbrushes into, and have a roll of kitchen towel handy....

Things get smelly and messy now. Gloves on, fan on, ventilation on. Ensure all your pots and mixers are to hand. Time is fairly critical.

If this is the first time you are mixing up a batch of Gel coat - get an empty clean tin. Into this pour in enough to fill it about a quarter full. The Gel coat is slightly pink. We want to make it black, so that the microballoons when mixed with the gel coat, doesn't show through to the top surface.

Add 1/4 of a teaspoon of pure black, and mix the 2 together. This tin of now black

gel coat, will last for many boomerangs. Put the lid back on the original gel coat, and put it back to storage.



Here, we have added the black pigment

Now fill a film pot with this black Gel coat. Get the hardener, and add 3% (0.6 ml) . Use your measuring syringe to do this. **Do not get this stuff any where near your skin and eyes.** Put the hardener and syringe safely away.

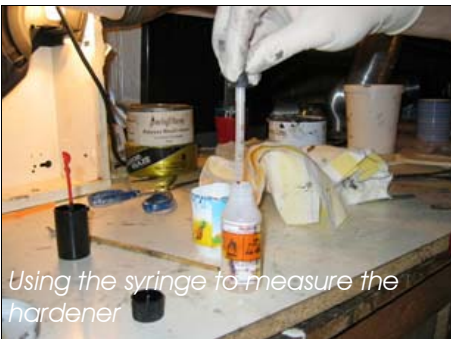

Using the syringe to measure the hardener



Transferring the Gel coat to a bigger pot

Move this mixture to a slightly bigger container (we used a cut down yogurt pot). Now give the Gel coat and hardener a good mix. Transfer 1/2 back to the film pot (stops it going hard so quickly).

6. Now to paint the Gel coat onto the mold. Do this carefully up to the edge of the impression in the mold. The black colour of the gel helps you to see where you are painting. This takes 5 minutes to do both halves of the mold. The mixture starts to go gloopy, the longer you work with it. if it becomes unworkable, mix up some more...



Painting on the Gel, to the mold surface.

7. Turn **over** the piece of paper with the outlines on



Painting the paper

(prepared in step 2). Paint some more gelcoat within the boomerang shape. The lines are quite visible through the paper. Roughly will do. Try to be quick.

8. Lay the carbon fibre onto the paper/gel coat. Lay **another** piece of paper onto the piece of carbon fibre. (So you now have a piece of carbon fibre sandwiched between two pieces of paper.) Turn the sandwich over, and cut out the shapes, *cutting to the inside of the lines.* Try to keep both bits of paper as still as possible..... it makes laying the carbon into the mold much easier.



Lay the carbon onto the gel paper



Turn it over, and cut to inside of lines

9. Now we have 2 cut out boomerang shapes of carbon, sandwiched between 2 bits of paper. Work out which piece of paper to peel off, so the carbon goes directly onto the gel coat of the mold, then once in the mold, using a brush, ease off the top piece of paper, taking care not to lift the carbon of the mold surface (see pictures). Then dab another coat of the Black Gel onto the carbon fibre surface.



The carbon is now in the mold, touching the gel...



Peel off paper, brush holds down carbon fibre



Add another coat of Gel

10. Adding the unidirectional carbon Fibre tape.....
(Prepared in Step 4)

Add some Vinyl Ester Resin to a film pot - about half of the pot. Add 0.2 ml of hardener. Mix it up.

Starting at the elbow, lay the strips into the mold, on top of the Carbon, dabbing on vinyl Ester, to help it stick. The uni tape has a tendency to fray, so try to minimise this. Once its laying in the mold, dab some Vinyl Ester on top of this.

Do both Mold halves.



The uni tape goes in from the elbow to the tip



Dabbing vinyl onto the uni tape

At this point, you would proceed immediately with the vacuum bagging. However if

you haven't the facilities to vaccum bag, then we would proceed to immediately add the balsa, and join the shells.

Vacuum Bagging

We are still quite new to this, but the initial results are encouraging. Vacuum bagging reduces the amount of airbubbles that can cause surface defects, thereby producing a better surface finish. It also reduces the weight, by getting rid of excess resin.

This link explains it better than I can !

http://www.info-central.org/construction_vacuumbagging.shtml

Just out of interest, I have a friend who has bought one of these FoodSaver gadgets from America, and has rigged it to run on our electricity voltage (240v).....

Hmmm

The vacuum pumps are expensive to buy from what I have seen on the internet. We used a converted fridge compressor. I am not sure how it was converted, but it



This is the converted fridge compressor...

looks fairly simple. The process is fairly straightforward. The mold (which is still wet), is put onto a solid surface -like a block of wood. Directly on top of the mold is placed the peel ply. On top of the peelply is placed the breather, which soaks up any excess resin. On top of the breather goes a thin layer of plastic called Bagging film. We used a supermarket fruit and veg bag. Ahem...

with a good sticky tape. One end of the bag was already sealed with tape by us - this end had the tube exiting, which sucks out all the air.

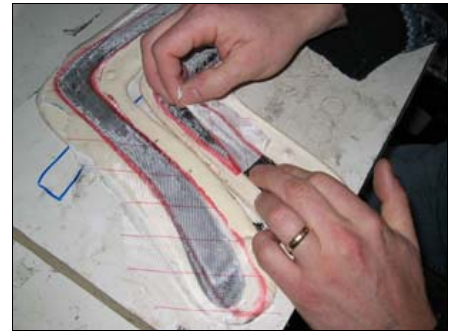

Job done, remove the peel ply



The business end is already sealed



Peel ply onto the wet carbon fibre

So basically once we inserted this all into the bag, we only had one end to seal with tape. You can buy bagging tape, or maybe use a glazing tape? Once its in and sealed, switch on the compressor for 2-4 hours. You will see the bag deflate under atmospheric pressure.

Filling the Shells

So now we have made the mold, created the shells, and maybe have been able to vacuum bag. Now to fill the mold, and join the two halves together. Add 10 ml of vinyl resin to the film pot. Add 0.2 ml of hardener. Mix it up well. Transfer to a bigger pot. Add 2 scoops of micro balloons, and mix to a pasty texture.



In goes the breather



Bye bye air... and hello leaks !

Now remember this is all sitting on top of a piece of wood. This is all inserted into a plastic bag, which we then sealed

After the process, undo the bag, remove the mold. Peel away the peel ply. One set of shells ready to fill.



Add 2 scoops of micro balloons



Mix in the micro balloons

Add a little black pigment, to stop any of the micro balloons from being visible on the MTA surface.

Apply this now black mixture, on top of the uni tape, spreading thinly onto the entire carbon surface. Aim to get the inner mold surface almost level and flush. Don't overfill. Take care to fill the edges of the mold.

Do both halves of the mold.



Spreading the micro balloons

Lay the balsa onto the correct mold, on top of the microballoon mix. Press the balsa down to make it stick (it may help to slightly slit the balsa top, to help it to bend here).



Lay the balsa down

Now use some more microballoons to fill in the gap between the balsa, and the edge of the carbon fibre.



Filling the gap between the balsa and edge...

Finally place the two halves of the mold together, and either clamp between 2 very thick pieces of wood, or use a heavy weight to apply the constant pressure.



The top goes on the mold at last...



Clamp between some thick unbendable wood..

Leave for at least 24 hours preferably in a warm room. And pray.

After its had time to cure, its the moment of truth - now to see how all your hard efforts have turned out.

Unfortunately, I cannot show you the picture of the boomerang that was produced from this set of pictures! because we ran short of time. I can tell you though, it was a beauty, with a 40 second flight resulting after a few throws.

Here is a picture though, that I took of a Triblader we had just released from the mold. All you do is to gently ease the mold apart, very much in the manner when we were making a mold, then tease



a Tri-blader just out of the mold...

the new boomerang out of the mold.

In the picture above, you can see where some of the resin has formed a white excess, this is easily trimmed away..... And thats it!

So now you know the techniques used for producing some very fine boomerangs. These same techniques can be used to make copy's of tribladers. The varying part will be what you fill the boomerang with - you can for example build coins for weights into the middle of the boomerang.

As I said, we are still learning, and I am sure you will find better ways of doing things. If so, then please share this information.

I am sure with more than just a few people worldwide making these types of boomerangs, some really good boomer-

angs will now result. What do you think ?

Good Luck with your experiments.

Regards

Adam
and Mart



Complete with dangerous chairs...



This is what a loft conversion should be for ! Boom lab ;)



PINCH GRIP VS. FULL GRIP | TIBOR HORVATH

Canada Tacky spray

It all started with a harmless message by David Hirsch, Texas:

*Guys,
Food for thought: I've found that a coat of Krylon Triple Gloss gives a 5-10% more tacky surface over simply paint alone thus allowing me to get more spin.*

In standard events there are lots of ways to mechanically improve adhesion of the boom - hand interface: roughen up paint, cover the wing with sandpaper, create specific surface structure. These are all means that can change the way your boomerang flies, so they are not used in Id.

That's when Rob Stewart, Pennsylvania enters the picture:

*David,
I agree with you - I discovered at the Shootout that the grip and feedback from the stickiness of the grip on the boom had a major influence in allowing me to release the boom where I wanted to. In the hot, humid Houston air it became a fine balance between my sweaty*

hands being too slippery or too sticky - I found myself frequently getting dust from the ground on my throwing hand to reduce the stickiness of my grip so I wouldn't release too late and throw into the ground. I sometimes envy the scientists who only have to put a spacecraft on the moon - they've got it made compared to throwing an LD! I'm starting to play with the full grip to try to go around some of the issues with the pinch grip.

Ah, yes, the good old full grip. Morri Mohr, California found this picture in the media gallery:



Manuel Schuetz throwing a voyager holding it with a full grip.

Mass of LD boomerangs over time

Now, who else is using a full grip to throw Id?

Before the 1980's, when Id boomerangs were in average above 140 g, there was only one way to throw these beasts, full grip.

I would say when Behrens and others started to work more on airfoil and less on adding weight, mass of Id booms came down to about 120g on average. These were the times when most people used one or two fingers grip. Not full grip anymore, but certainly not pinch grip either.

With the arrival of the MegaQuirl and all its variations (Buzz Whip, Voyager, etc.) that we are using today, the mass went down again, to an average of about 70g. I remember seeing Axel Heckner throw his MegaQuirl for the first time, pinching it. So did David Schummy. (if you have the Id book, check out the graph at page 22 in the 3rd edition for a more visual explanation of how mass and wing span went down over time) However, the current world record holder and dominator of any Id competition is

throwing full grip.

Pros and cons by Rob Stewart



The pinch grip.

Pinch grip advantages:

- 1) Allows the boom to be located farther out on the release mechanism (my arm), which should translate into a higher velocity at release.
- 2) Allows the boom to be cocked back over my forearm, which should generate extra spin at release, assuming I modulate the pressure of the pinch precisely such that the boom snaps out of the grip at just the right time (to accurately place the boom in the window I'm shooting for) and with the highest rate of spin.
- 3) It's a more natural grip for me because it's the way I throw sports booms.

Pinch grip disadvantages:

- 1) Seems to require a very tightly controlled interface environment between the fingers and the upper and

lower surfaces of the boom. See the recent thread on stickiness of the surface - high gloss Krylon, surf board wax, dust. For me, if my hands are sweaty, it's a challenge to get that interface just right.



The full grip.

(Potential) Full grip advantages:

- 1) It might be a way for me to generate extra spin if I can figure out the mechanics to use my fingers as a "trigger" at release.
- 2) By reducing the dependency on the fine balance of pinch pressure, stickiness of the surfaces and timing of the release of the pinch, it may be easier to hit the "window" and make the boom go closer to where I want it to go.

Full grip disadvantages:

- 1) With full grip the boom is located closer to my body and I give up some forward speed at release.
- 2) I may not be able to figure out the extra "trigger" action to generate the additional spin.

- 3) The full grip may place more stress on my wrist to generate part of the snap at release - this could expose an integral part of my bio-mechanical throwing mechanism to premature wear, and I already have an uphill battle there.
- 4) Learning curve issues associated with my lack of time to get out and throw.

First reaction to change

Johnny, Calgary:
you are thinking way to much...just throw the darn thing ..let it happen...and last but not least.. i pinch grip every boom...except big old woodklunkers that need some ummmmmmmppppfffffff. ..don't worry about your mechanism rob...the boom will tell you if you need to pinch it or punch it...its that easy or hard as you want to make it...imho...

David Hirsch, Texas:
Well, I did try modifying my grip when throwing today and a full grip for a Voyager just wasn't working for me. Obviously, if I wanted to switch grips it would take more than one days' effort. But I've always felt that there was a particular grip for a particular boom; for me, a pinched grip affords more

control than full on a Voyager. Ricardo, I had to dull the edges on the first booms I made on the throwing arm to keep from getting sliced :-); when I first started, I was making them too sharp and it was slicing the base of my thumb as I let it go!

If you observe the way people hold a pen or pencil, some people do a wonderful job with a grip that just looks painful but in the end the results are what counts. I've mentioned before that I've played percussion all my life; there are several different grips for those sticks as well but when you teach a new student it's balance, heft and control that are the goals. I'd say it's similar for booms; there should be a balance and despite the energy expended on the throw it shouldn't be a strain (though the faces we make when throwing might suggest otherwise). There is a certain "zen" to the experience and you want to enjoy what you're doing, to become one with the boom :-). Rob's got the right approach; careful and critical examination - if I was starting from scratch I might do more experimentation. And I understand Johnny's point of having fun and being in the moment but it's like many other things; if you want to

do it right, good rudimentary skills are necessary first. My Dad was right about that, darn him!

As to Ricardo's comment about throwing on a rainy day... well, I guess I'd just be out of luck :-). Though I could get my snowboard wax out and see if that would help... If I could throw well with a full grip and it would get me 10 more meters, I'd switch right now... maybe I just need my own Twinkie shrine... I'll have to put my medicine rocks in my pocket next time. So anyway, I've made the attempt. New ideas keep you young!

Testimonials of full grippers

Manuel Schuetz, Switzerland: When I started throwing boomerangs I always threw pinch grip. But during the years my grip changed very slowly, first using one finger in front, ending up with 2-3 fingers in front. Thank you, Willi Urban! Your "Comeback" forced me to learn that grip. But light MTAs I still throw pinch grip. They are not controllable using full hand grip! But for LD pinch grip has no chance for throws of >170m and even >150m is difficult because:

1. The contact between boomerang and throwing hand is "flexible". During the throw the

boom slides around in your hand. Only few mm of sliding are enough to get a high loss of velocity and precision suffers. LD booms are just too heavy for pinch grip, whereas 13-17g MTAs are made for the pinch grip!

2. I'm able to throw both pinch and full hand and once threw a Buzzwhip in competition using pinch grip. Result: 115m and no chance to get further! Full-hand grip: 153m. For both throws I used my maximum Power...

3. Fred Declercq's booms were stolen in Roma 2003 during EBC. What this has to do with LD?

Well: Fred had to make new boomerangs and decided to change the grip from pinch to full hand (!). The effort is visible: His throw has become much more constant and he's able to throw many of my boomerangs because his spin has become better. And: At the EBC in Cologne he got 2nd in LD with a throw of 116m in very bad conditions.

Conclusion: Give that grip a definitive chance for LD! But: Don't necessarily start with LD booms but try with a 20m boomerang which is definitively too heavy for a pinch

grip. Extreme example: The "Comeback" by Willi Urban (176g). With such a boomerang you're forced to throw full hand.

And by the way: I suppose that hunting sticks (200g up to 800g) were thrown full handed by the aborigines and they did it well and precise with a brute force: They're culture survived until the white men came (a tough sentence but true...). It will take you probably more than 1 afternoon to master that grip.

*Adam McLaughlin, GB:
For a long time I only threw pinch grip on LD, or perhaps one finger over the end. Lorenz told me that Manu threw full grip (as in the picture on recent link). I tried this new full grip, and for a while it felt really uncomfortable and quite alien. However I recommend you persevere, there is no doubt that significantly more power can be achieved on release.
The pinch grip is not firm enough to maintain grip for the LD throw.
I would say that after about an hour of practice, I was reasonably happy. First few throws were way scary though, I tended to ground them early and things were worrying out of control.*

I was able to take 115 m throws to 130-140 m, and now never throw any LD using pinch grip.

Why you should give the full grip a chance

*Of course, results may vary, especially with boom throwing, the relationship boomerang - thrower is very important.
But there seems to be an indication that full grip, even though it feels strange on such a light boomerang as the Voyager, might increase your range. It might increase your spin. It might just spawn more thoughts about why some boomerangs work for you, and others don't.
Personally, I have seen Schummy throw a pinch grip Buzz Whip over 174m. I have seen Schuetz throw full grip over 238m. In the end, it makes sense to revisit all aspects of the throw, pinch vs. full is just one variable. Future articles here will focus on some other important aspects of the throw and the boom.*

Comments from Laurent to this article:

Very interesting article about grip... I will test again the full grip method, "just to see".

Throwing very lightweight LD

*booms (55-60g), I definitely chose pinch grip years ago. I don't know if it is the true pinch grip style, as I use 3 fingers. But it is true it can only work with a "controlled" gloss and surface aspect : I spray always the same brand of paint on the leading arm hand . I have found a brand which is not especially a good quality one, but it has the just the perfect glossy, tacky touch for my throwing style.
In tournaments I always have some water to wash my hands before throwing. I know that Antoine Hernandez does that too.*

Some throwers use a kind of natural tree rosin (like the one handball players use) but tried once and I just hated it.

About the full-grip method, there is at least one other powerful thrower to use it: Uwe Kitzberger has a unique grip style, with maybe just 3 fingers but basically it is like the full grip: he takes the boom not at the tip end, but a little higher and with fingers very clenched around the boom arm. I think this full grip is quite normal for his rather heavy booms (more or less 80g if I remember well)